

THE BARTON CENTER

**MAY
NEWSLETTER**

2024



**216-221-3400
14300 DETROIT AVE.
LAKEWOOD, OH 44107**

WWW.BARTONCOMMUNITIES.ORG

TABLE OF CONTENTS



03 Updates

13 Community Group Activities

20 Creative Therapies

21 Religion & Worship Group Activities

22 Lakewood Community Activity

22 Support Groups

23 Health & Wellness

27 Additional Events & Resources

30 Contacts & Shop Hours



**Would you like the newsletter delivered to
your email each month?**

See Christina or email her at:

cstover@bartoncommunities.org!

\$7 Lunch Delivery

3

Residents can choose from two options that will be delivered each Thursday at 11:30 a.m.

Residents are required to pre-pay for meals by 12 p.m. noon on Tuesday each week.

Meals can be prepaid at The Corner Store.

May 2nd Menu:

Greek lemon chicken and rice w/ spinach, crumbled feta, sun dried tomatoes, and spices, garden salad w/ lemon vinaigrette, roll w/ butter, and oatmeal raisin cookie.

May 9th Menu:

Old-fashioned meatloaf w/ brown gravy, cinnamon applesauce, peas & carrots, mashed potatoes, and fudge brownie.

May 16th Menu:

Chicken salad croissant, pickled cucumber salad, minestrone soup, and Funfetti cookie.

Check with Christina in the Barton Center Office for the other May lunches!



May Movie Days

4

2001: A Space Odyssey vs. Apollo 13

When: Monday, May 6th

Where: Faulhaber Auditorium

Time: 2 p.m. - 4 p.m.

Vote for your pick in the Carr lounge!

Popcorn will be provided!

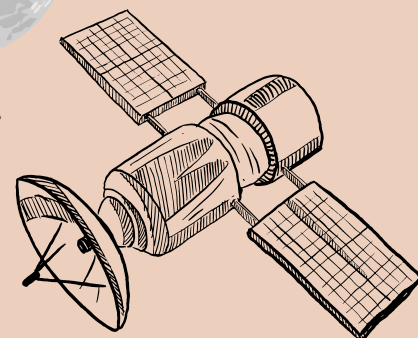

Walk in the Woods vs. Wild

When: Tuesday, May 13th

Where: Faulhaber Auditorium

Time: 11 a.m. - 3 p.m.

Vote for your pick in the Carr lounge!

Popcorn will be provided!



MH370: The Plane that Disappeared vs.

Downfall: The Case Against Boeing

When: Monday, May 20th

Where: Faulhaber Auditorium

Time: 2 p.m. - 4 p.m.

Vote for your pick in the Carr lounge!

Popcorn will be provided!

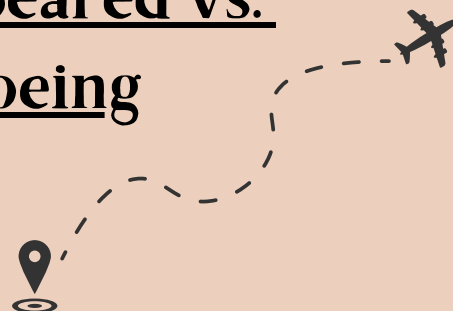

May Crafts

5

Fabric Crafts

When: Thursday, May 2nd

Where: Craft Room

Time: 1 p.m. - 3 p.m.

Come make tote bags and pillows!



Tie Dye

When: Thursday, May 9th

Where: Craft Room

Time: 1 p.m. - 3 p.m.

Come tie dye with us! Residents are welcome to bring their own materials or help Barton Center create items for the Lakewood Arts Festival in August.

Bob Ross Painting Tutorial

When: Thursday, May 16th

Where: Craft Room

Time: 1 p.m. - 3 p.m.

Come follow a Bob Ross painting tutorial with us!



Stress Balls

When: Thursday, May 23rd

Where: Craft Room

Time: 1 p.m. - 3 p.m.

Come make aromatherapy stress balls with us!



Perler Beads Craft

When: Thursday, May 30th

Where: Craft Room

Time: 1 p.m. - 3 p.m.

Come make fun and colorful designs with beads!

Residents MUST pre-register for ALL crafts on the Craft Room door.

See Barton Staff with questions!

May Activities

Food Bank Distribution - Cleveland Food Bank

When: Friday, May 3rd

Where: Cafe

Time: 10 a.m. - 12 p.m.

You must pre-register

Contact: Christina at (216) 221-3400
ext. 136



Taco Monday

When: Monday, May 6th

Where: Cafe

Time: 11:30 a.m. - 1 p.m.

Join us for a tasty lunch provided by staff members and then vote for your favorite! Everyone is welcome!

Devoted Event

Devoted Healthcare will be on Wednesday, May 15th from 1 p.m. - 2 p.m. in the Cafe for Straw Hat Day and will be providing chocolate cookies and flowers at this event. They will also be here to discuss healthcare and answer any questions you may have!



May Activities

PC's for People

When: Wednesday, May 15th

Time: 10 a.m. - 2 p.m.

Where: Cafe

Representatives will be in the cafeteria to answer any internet questions.



May Birthdays & Jeopardy

will be celebrated on Friday, May 24th, in the Cafe from 3 p.m. - 4 p.m. Cake will be provided!

Prize Bingo

will be on Wednesdays, May 1st and 22nd at 1 p.m. - 2 p.m. and take place in the Cafe. Come join Shanez and friends to win fun prizes!

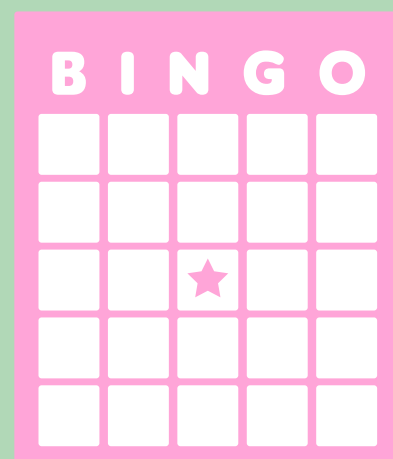

Additional May Events

Smart TV 101 Presentation

will be on Tuesdays, May 14th and 28th at 1 p.m. - 2 p.m. and take place in the Cafe. Come join Shanez to learn all about Roku streaming, Firesticks, and your smart TV. All are welcome!



Intergenerational School

will be coming on Monday, May 6th, Friday, May 10th, Monday, May 13th, and Friday, May 17th in the Cafe from 10:15 a.m. - 11:15 a.m. School students will be planning icebreakers, games, crafts, and much more!



M2B2 Band Rehearsals

are on Thursday, May 9th and the 23rd in the Faulhaber Auditorium from 7 p.m. - 9 p.m. All are welcomed!



Free Hearing &

Hearing Aid Checks



When: Monday, May 6th

Time: 10 a.m. - 4 p.m.

Where: Wellness Center

Call now to schedule your appointment!

Earl Gentile - 440-333-3271



CSC LAKEWOOD Community
Services Center

YOU'RE INVITED

to À La Cart, a series of live cooking demos by local celebrity chefs.

WHEN & WHERE

Tuesday, May 14th @ 2 p.m.

Cove Community Center
12525 Lake Avenue

FEATURING

Ben Bebenroth

Chef/Founder, Spice Hospitality Group

Chef/Owner, Boom's Pizza





10

Smoking Cessation Presentation

When: Wednesday, May 29th

Time: 1 p.m. - 2 p.m.

Where: Cafe

Join the Visiting Nurse Association of Ohio for a presentation on the best tips and tricks to stop smoking.

Friday Trivia w/ the Walden's

When: Friday, May 31st

Time: 2 p.m. - 3:30 p.m.

Where: Cafe





We Can Help



You MUST sign up in advanced. See Barton Staff to sign up for a 15-minute slot.

Sign Up to receive Free One-on-One Tech Support with IConnect
Date: Tuesday, May 7th
Time: 2 p.m. - 4 p.m.
Where: Cafe

- Questions on your new device?
- Need help downloading games or apps?
- Want to know how to check or send email?
- Want to watch a movie on your tablet?
- Questions on saving pictures?
- Trouble with storage?



1 2



Nails by NaS LLC

Mother's Day Mani~Pedi

Treating your mom to a manicure
and pedicure special is a
fantastic way to show her love and
appreciation on Mother's Day.



Manicures \$22
Pedicures \$46

Friday, May 10th
3 p.m. ~ 5 p.m.

**Please see Barton Center to sign up
for your 30-minute time slot!**

Beautybynas.my.canva.site

Community Member

1 3

Group Activities



Coffee With Friends

When: Every Saturday

Time: 9 a.m. - 11 a.m.

Where: Cafe

Enjoy some coffee and get to know someone new!

Stories On Paper

When: Wednesdays,
May 8th & 22nd

Time: 10 a.m. - 12 p.m.

Where: Faulhaber Auditorium

Participants are given a creative prompt to write a short story that can be shared with the group. Come write and chat with us!



Lunch & Chat

When: Every Thursday

Time: 11:30 a.m. - 1 p.m.

Where: Cafe

Bring your own lunch and get to know someone new!

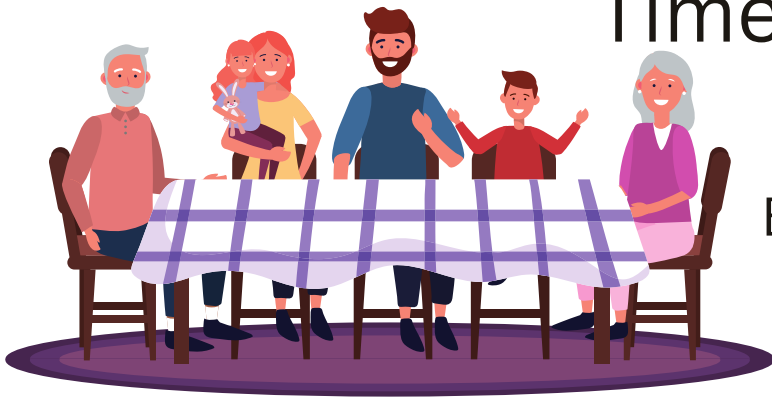

Book Project

When: Every Thursday

Time: 9 a.m. - 11 a.m.

Where: Craft Room

Repurpose greeting cards and make picture books for children.

All materials are provided!

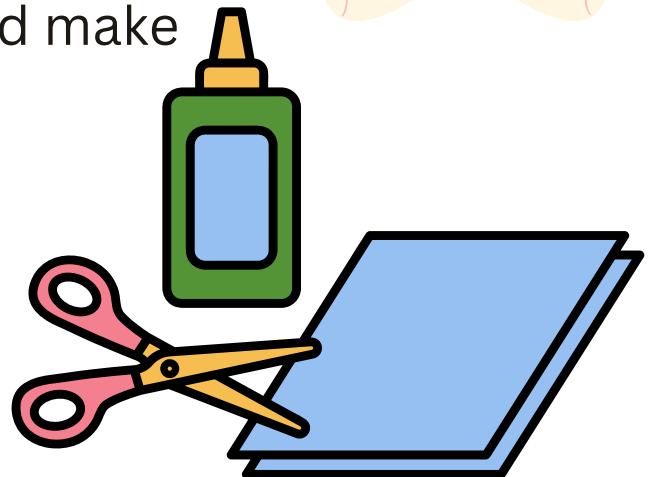

1 5

Book Club

When: Wednesdays, May 1st and 15th

Where: Craft Room

Time: 1 p.m. - 3 p.m.
with Christina



Lakewood Public Library: Homebound Service

When: Every Tuesday

Time: 10:30 a.m. - 12 p.m.



Call LPL Customer Service Desk by 6 p.m. the Saturday before your delivery date at: (216) 226-8275 ext. 110.

Library representative available to receive books to be returned at this time in the Cafe area.



Open Craft Room Hours

When: Every Monday

Where: Craft Room

Time: 9 a.m. - 12 p.m.

Come hang out and work on
your crafts!



Wednesday Morning Coffee

When: Every Wednesday

Where: Cafe

Time: 8:30 a.m. - 10 a.m.



Tabletop Bowling

When: Wednesday, May 8th

Time: 1 p.m. - 3 p.m.

Where: Cafe

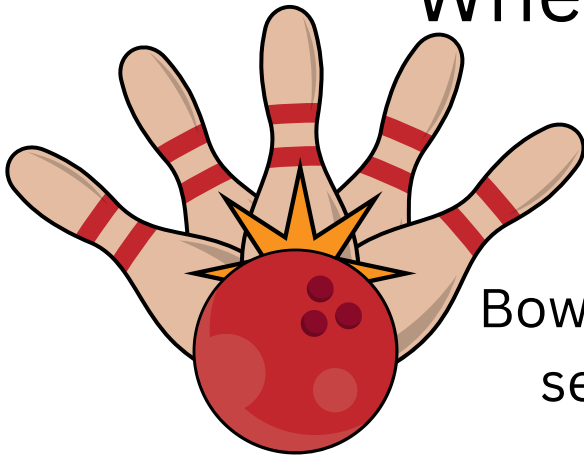

Bowlers join us for the last game of the season and an end of the year party!

Rummikub Game Play

When: Every Friday

Where: Cafe

Time: 10 a.m. - 12 p.m.

Join residents in the Cafe every Friday to play Rummikub!

Everyone is welcome!



Karaoke

When: Saturdays, May 4th & 18th

Time: 6:30 p.m. - 8 p.m.

Where: Cafe
with Ron Walden



Sunday Jams

When: Every Sunday

Time: 1 p.m. - 6 p.m.

Where: Community Room
with Honey





Janis & Tony

When: Sundays,
May 12th & 26th

Time: 6:30 p.m. - 8 p.m.

Where: Brosky Commons

This duo performs 40's and 50's music.

Janis plays the piano, and Tony sings standards and show tunes. All are welcome!

Janis & Peter

When: Thursdays,
May 2nd & 16th

Time: 7 p.m. - 8:30 p.m.

Where: Brosky Commons

This duo performs light classical music. Janis plays the piano and Peter plays the violin.

All are welcome!

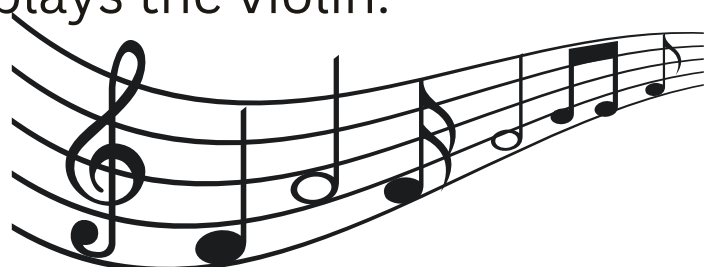

Creative

20

Therapy Activities



Music Therapy

When: Every Thursday

Time: 2:30 p.m. - 3:30 p.m.

Where: Community Room
with Gavin

Art Therapy

When: Every Monday

Time: 4 p.m. - 5:30 p.m.

Where: Community Room
with K.D.



NO ART THERAPY ON MONDAY, MAY 27TH

Religion & Worship

21

Activities



Rosary Services

When: Every Tuesday

Time: 7 p.m. - 8 p.m.

Where: Community Room
with Ms. Tyburski

Bible Study

When: Wednesdays,

May 8th & May 22nd

Time: 10 a.m. - 11:30 a.m.

Where: Community Room
with Ron Walden



Lakewood

2 2

Community Activities

Lakewood Black Caucus



When: Saturday, May 18th

Time: 12 p.m. - 2 p.m.

Where: Lakewood
Presbyterian Church

with Ms. Wellborn & Ms. Hill

Enter in the rear of the church. FREE parking.

Support Groups

Parkinsons Support Group

When: Wednesday, May 15th

Time: 11 a.m. - 12 p.m.

Where: Community Room
with Steve Gannis

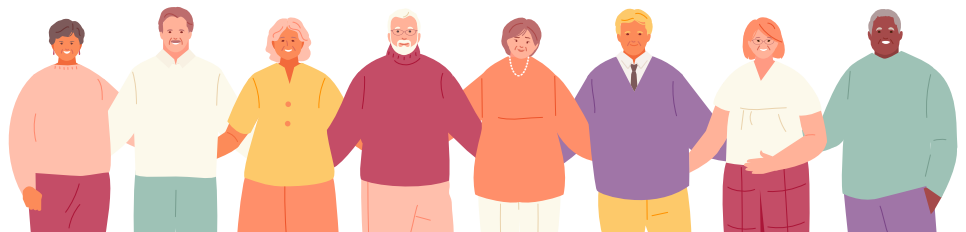

Health & Wellness

2 3

Activities

Stretching into Health w/ Cat Donovan

When: Every Tuesday

Time: 10 a.m. - 10:45 a.m.

Where: Community Room

Stretching into Health is gentle stretching that is done while seated or using a chair for balance.



Tai Chi w/ Jan

When: Every Thursday

Time: 11 a.m. - 11:45 a.m.

Where: Greenhouse

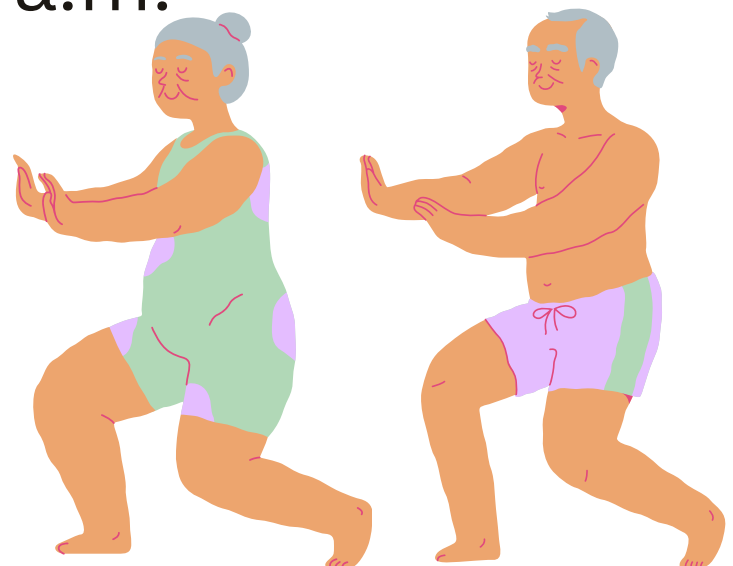

Barton Center

24

Wellness Corner

Neighborhood Paramedic

**Blood Pressure and Glucose Checks
And**

**Remember When: Fire & Fall Presentation
with Ryan Birth & Assistant**

When: Tuesday, May 8th

Time: 10 a.m. - 11 a.m.

Where: Cafe

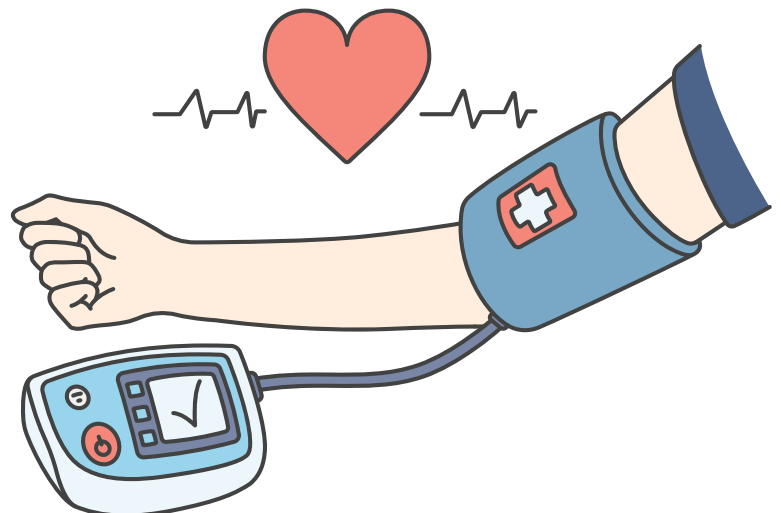
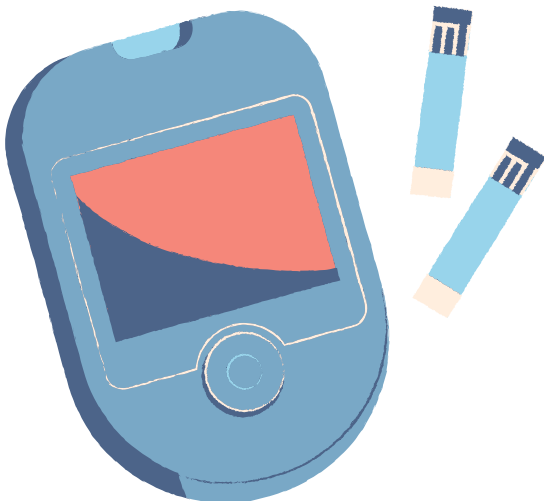

Wellness Center Offerings

Dr. Mark Massie
Podiatrist

When: Every 3rd
Thursday

Time: 9 a.m. - 3 p.m.

By appointment ONLY
216-402-4233



Anthony Lima
Licensed Massage
Therapist

By appointment ONLY

Call or Text:
216-704-0794

Email:
GITmassage@hotmail.com



Fitness Center

26

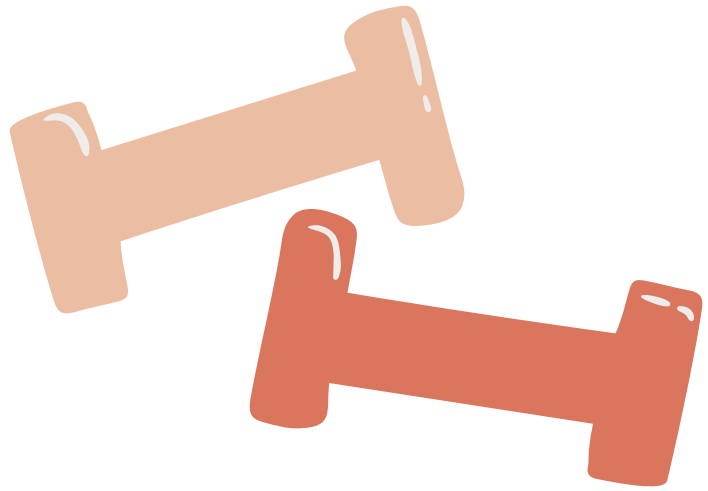

OPEN 24 HOURS

Please see the Westerly Office, room 110, to sign a waiver and activate your fob. **A waiver must be completed prior to using the Fitness Center.**



Barton Center Transportation



Services

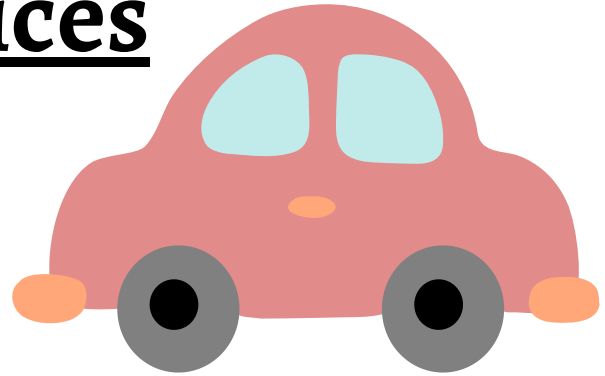

(216) 221-4282

COST: \$2 one-way \$4 roundtrip

Monday-Friday 9 a.m.-11:15 a.m.

1 p.m. - 3:15 p.m.

Must book in ADVANCE

Next Westgate Trip: Wednesday, May 8th

Must be able to get in and out of the car independently. The Barton Center is not responsible for any **lost, stolen or damaged items.**

You must be on time for your ride, or the car will leave without you!!



How the Arts Enrich Brain Health

With speaker Nadine Kodysz from
The Carolyn L. Farrell Foundation for Brain Health
On Friday, May 10th from 1:30 - 2:30 p.m.
in the Cafe





How Sweet It Is:

**A Discussion on How to Self-Manage
Diabetes with a Focus on a Healthy
Lifestyle through Nutrition, Exercise,
and Stress Management**

With speaker Dr. Riquetta Carpenter from
The Western Reserve Area Agency on Aging

On Friday, May 24th from 1:30 - 2:30 p.m.
in the Cafe



Western Reserve
Area Agency on Aging

BARTON CENTER CONTACTS

Allison

Executive Director

216-521-7260 ext. 128

Annie

Activities Coordinator

216-221-3400 ext. 134

Christina

Activities Coordinator

216-221-3400 ext. 136

Shanez

Activities Coordinator

216-221-3400 ext. 132

Barton Center offices
will be CLOSED on
Monday, May 27th.



BARTON CENTER SHOPS

The Library

Hours: Monday - Friday
9 a.m. - 8 p.m.
Key FOB Entry

Book Sign-Out Steps

1. Sign author card with name/date/apt # (non-residents) please include phone number.
2. Put 1st card in box on desk. Due Date: 2nd card, keep in book. PLEASE

Salon & Barber Shop

Hours: Thursdays & Fridays
9 a.m. - 2 p.m.
Call: Chris Fordyce to schedule appointment.
(216) 287-6634

The Corner Store

Hours: Monday 10 a.m. - 12 p.m.
Tuesday - Thursday 10 a.m. - 3 p.m.

Hodge Podge Resale Shop

Hours: Monday 10 a.m. - 12 p.m.
& Wednesday 9 a.m. - 2:30 p.m.

Book Nook

Hours: Tuesday & Thursday
9:30 a.m. - 2:30 p.m.
A wide selection of gently used
and new books!

